

<b>Subject:</b>  <b>FRONT BRAKE CREAKING AT LOW SPEEDS</b>	<b>Bulletin No:</b> 04-001/09
	<b>Last Issued:</b> 2/12/2009

## BULLETIN NOTE

- This bulletin supersedes the previous bulletin 04-004/07, issued 8/3/2007. The REPAIR PROCEDURE, PART(S) INFORMATION and WARRANTY INFORMATION sections have been revised.
- Changes are noted below in Red beside the change bar.

## APPLICABLE MODEL(S)/VINS

2006-2007 MX-5 with VINs before JM1 NC\*\*\*\* \*\* 131172 (built before November 10, 2006)

## DESCRIPTION

Some vehicles may exhibit a creaking noise when the brake pedal is gently depressed while driving at low speeds. The creaking noise is due to resonance of the front brake pad guide plate. The thickness of the guide plates have been increased to correct this concern.

Customers having this concern should have their vehicle repaired using the following repair procedure.

## REPAIR PROCEDURE

1. Verify customer concern.
2. Replace front caliper pad sub set with modified parts (A). Refer to MS3 online service information or Workshop Manual section 04-11 DISC PAD (FRONT) REPLACEMENT. Reuse the existing attachment plates (shims) (B) when installing the modified parts.

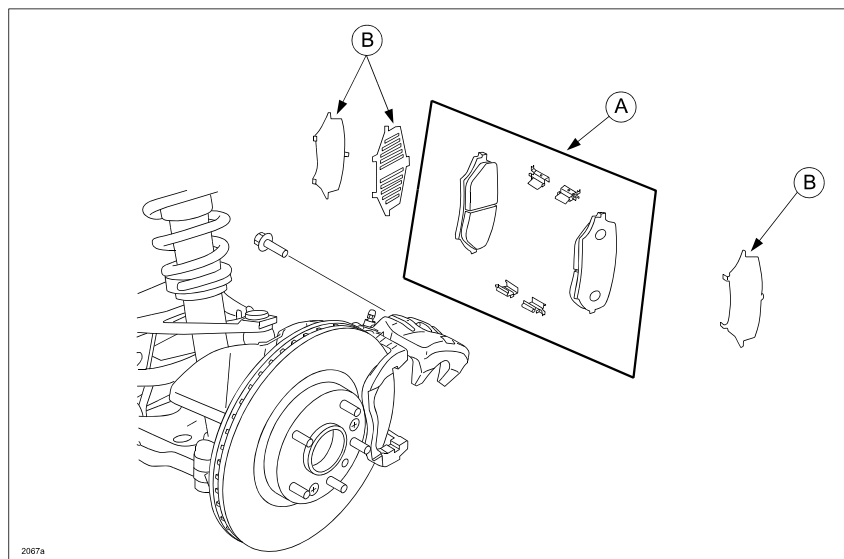

3. Verify repair.

<b>Bulletin No:</b> 04-001/09 © 2009 Mazda Motor of America, Inc.	<b>Last Issued:</b> 2/12/2009
----------------------------------------------------------------------	-------------------------------

## PART(S) INFORMATION

Part Number	Description	Qty.	Notes
NFY7-33-28ZC	Pad Sub Set	1	---

## WARRANTY INFORMATION

### NOTE:

- This warranty information applies only to verified customer complaints on vehicles eligible for warranty repair.
- Additional diagnostic time cannot be claimed for this repair.
- Repairs for the condition described above will be warranted by Mazda for a term of 12 months/12,000 miles, which ever occurs first.

Warranty Type	A
Symptom Code	35
Damage Code	9E
Part Number Main Cause	NFY7-33-28ZC
Quantity	1
Operation Number / Labor Hours:	XXC1AXRX / 0.6 Hrs