

Section <b>07</b>	Applicable Model/s <b>1995-98 Protege 1996-97 Miata</b>	Subject <b>A/C INOPERATIVE - P/S PRESSURE SWITCH TERMINAL ASSEMBLY CORRODED</b>	Bulletin No. <b>001/00</b>
			Issued <b>02/07/00</b>
			Revised

## BULLETIN NOTE

- This bulletin supersedes 07-001/99. The WARRANTY INFORMATION has changed.

## APPLICABLE MODEL(S)/VINS

1995-98 Protege with a "BP" or "Z5" engine and VINs lower than JM1 BC14\*\* W0182001.

1996-97 Miata with VINs lower than JM1 NA35\*\* V0739029.

## DESCRIPTION

Some vehicles may exhibit the air conditioning (A/C) system inoperative with the Malfunction Indicator lamp (MIL) ON. This may be due to the Power Steering Pressure (PSP) switch terminal assembly becoming corroded causing the Powertrain Control Module (PCM) to open the A/C relay circuit and set Diagnostic Trouble Code (DTC) P0550. A modified PSP switch terminal assembly is available to resolve this concern.

Customers having this concern should have their vehicle repaired using the following procedure.

## REPAIR PROCEDURE

- Verify customer concern.
- Turn the A/C system ON and disconnect the PSP switch.
  - If the A/C system does not function, refer to the Workshop Manual for troubleshooting and repair information.
  - If the A/C system operates, replace only the PSP switch terminal assembly.

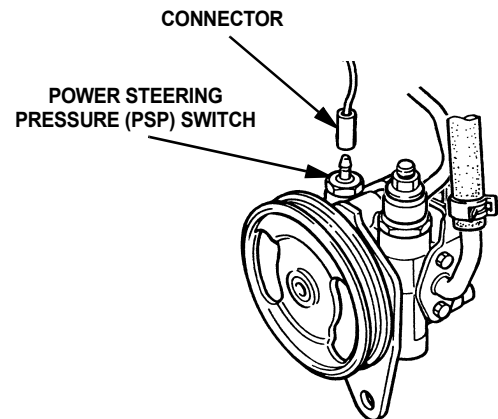

## Note

- Replace only the terminal assembly. Do not replace the entire PSP switch.

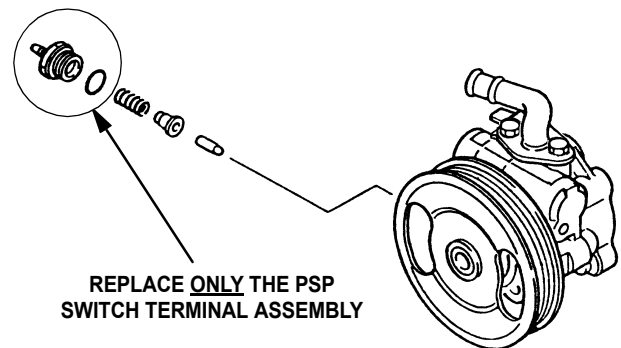

- Verify repair.

**CONSUMER NOTICE:** The information and instructions in this bulletin are intended for use by skilled technicians. Mazda technicians utilize the proper tools / equipment and take training to correctly and safely maintain Mazda vehicles. These instructions should not be performed by "do-it-yourselfers." Consumers should not assume this bulletin applies to their vehicle or that their vehicle will develop the described concern. To determine if the information applies, consumers should contact their nearest authorized Mazda dealership.

<b>Number: 07 - 001/00</b>	<b>Date Issued: 02/07/00</b>	<b>Revised:</b>
----------------------------	------------------------------	-----------------

**PART(S) INFORMATION**

Part Number	Description	Qty.	Notes
BC1D 32 234A	Power Steering Pressure Switch Terminal Assembly	1	---

**WARRANTY INFORMATION**

**Note**

- This information applies to verified customer complaints on vehicles covered under normal warranty. Refer to the SRT microfiche for warranty term information.

Warranty Type	A
Symptom Code	6X
Damage Code	93
Part Number Main Cause	BC1D 32 234A
Quantity	1
Operation Number / Labor Hours	XX094XRX / 0.6 (terminal assembly replacement)