

© 2008 Mazda Motor of America, Inc.

Subject: POWER RETRACTABLE HARD TOP (PRHT) - RATTLE FROM WINDSHIELD HEADER AND ROOF PANEL WHILE DRIVING	Bulletin No: 09-035/08
	Last Issued: 10/15/2008

APPLICABLE MODEL(S)/VINS

2007-2008 MX-5 PRHT vehicles with VINs lower than JM1 NC**** ** 148630 (built before January 11, 2008)

DESCRIPTION

On some vehicles the windshield header and roof panel may rattle while driving. The cause is the latching force between the top lock and striker is not sufficient. As a mass-production change, the latching force has been increased.

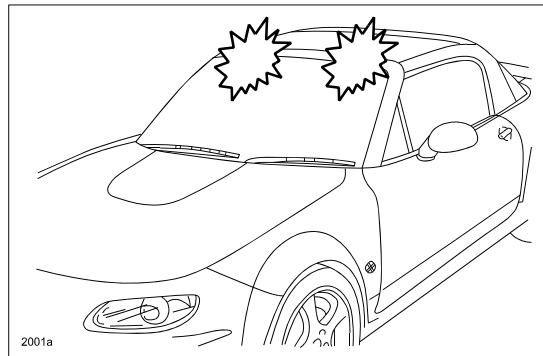

Customers having this concern should have their vehicle repaired using the following repair procedure.

REPAIR PROCEDURE

NOTE:

- The following procedure outlines tightening the top lock adjustment nut by one turn.
1. Verify customer concern.
 2. Remove the top lock spring (A) from the pin (C).
 3. Remove snap ring (B) from pin (C) using snap ring pliers, then remove the pin.

CONSUMER NOTICE: The information and instructions in this bulletin are intended for use by skilled technicians. Mazda technicians utilize the proper tools/equipment and take training to correctly and safely maintain Mazda vehicles. These instructions should not be performed by "do-it-yourselfers." Customers should not assume this bulletin applies to their vehicle or that their vehicle will develop the described concern. To determine if the information applies, customers should contact their nearest authorized Mazda dealership. Mazda North American Operations reserves the right to alter the specifications and contents of this bulletin without obligation or advance notice. All rights reserved. No part of this bulletin may be reproduced in any form or by any means, electronic or mechanical---including photocopying and recording and the use of any kind of information storage and retrieval system ---without permission in writing.

4. Remove the two screws (D) from the cover (E).

NOTE:

- The screw threads are coated with Loctite, removal may be difficult.
- If the screws are damaged or stripped during removal, replace as necessary.

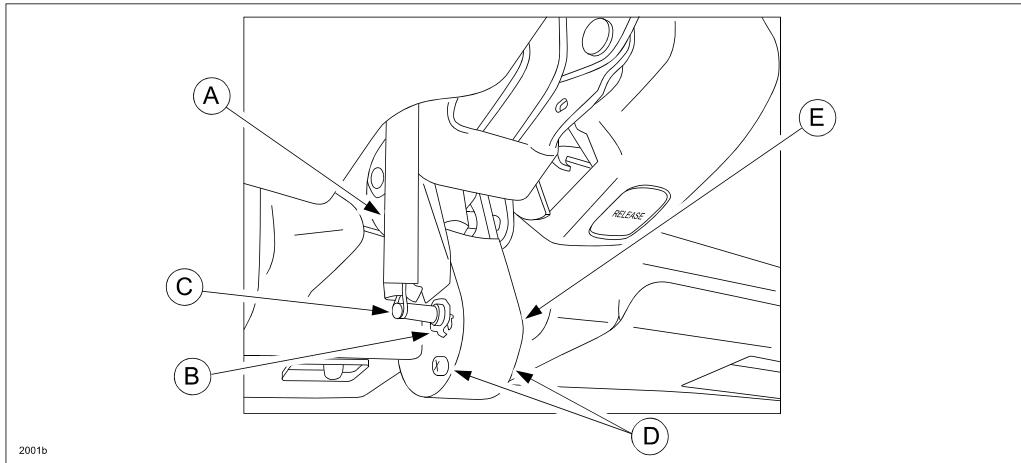

5. Remove the cover (E) from the top lock (F).

NOTE:

- If the top lock cover is broken, replace as necessary.

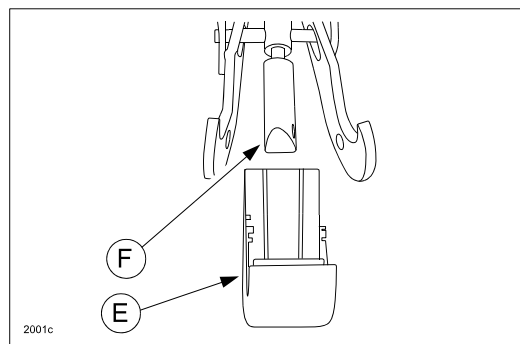

6. Turn the adjustment nut (G) clockwise by one complete turn (360°) to increase the latching force.

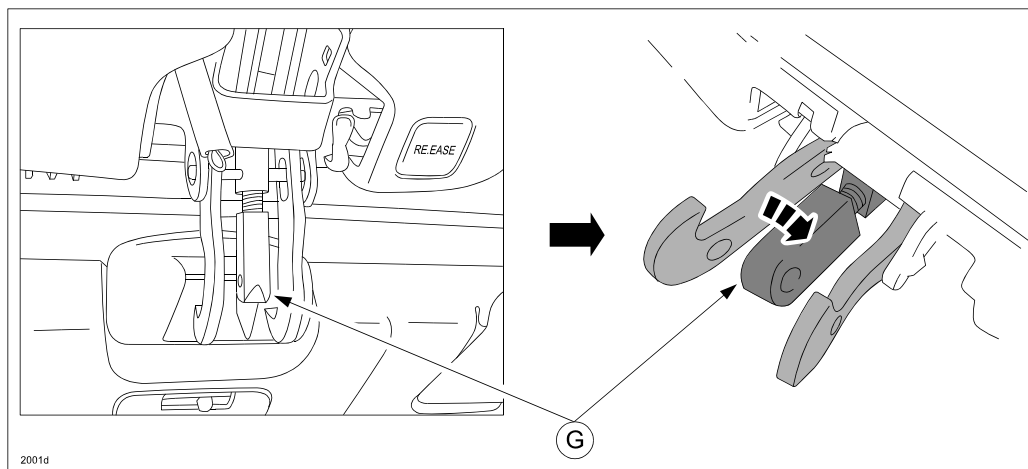

7. Reinstall the cover (E) to the top lock and tighten the screws (D).

NOTE:

- Apply Loctite to the screw threads.

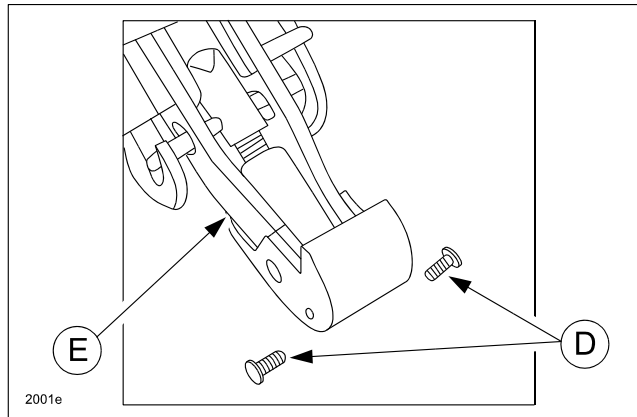

8. Insert the pin (C) into the top lock.

9. Reinstall the snap ring (B) using the snap ring pliers.

NOTE:

- After securing the snap ring, ensure there is no play between the snap ring and pin.
- If the snap ring breaks or is broken, replace as necessary.

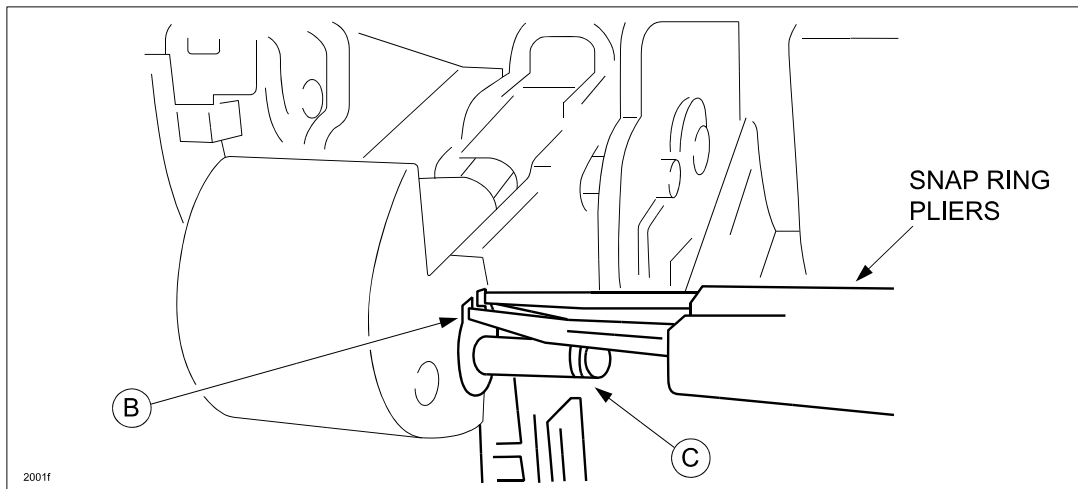

10. Install the top lock spring (A) to the pin (C).

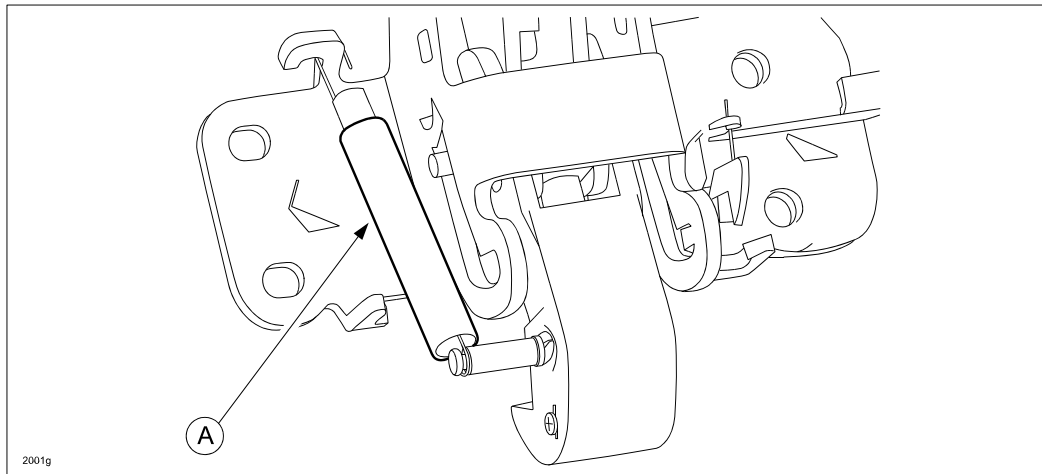

11. Check the clearance (A) between the roof panel (1) and windshield header (2).

- **(A) = 4-8mm**

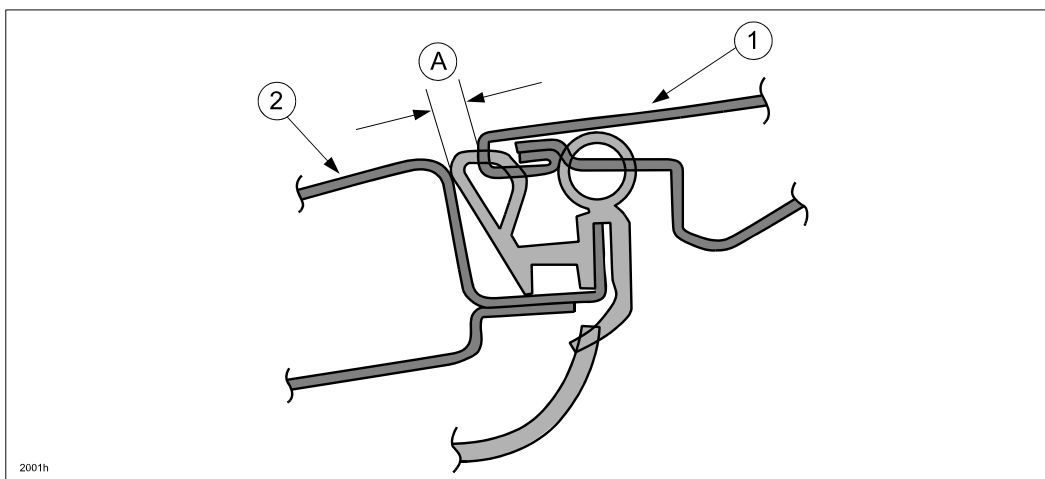

12. Verify repair.

WARRANTY INFORMATION

NOTE:

- This warranty information applies only to verified customer complaints on vehicles eligible for warranty repair.
- This repair will be covered under Mazda's New Vehicle Limited Warranty term.
- Additional diagnostic time cannot be claimed for this repair.

Warranty Type	A
Symptom Code	82
Damage Code	97
Part Number Main Cause	7777-SP-D0C
Quantity	0
Operation Number / Labor Hours:	XXD47XTX / 0.3 Hrs.